

## JEE-Main Exam April, 2019 / 12-4-19 / Evening session

### Physics

- The electron in a hydrogen atom first jumps from the third excited state to the second excited state and subsequently to the first excited state. The ratio of the respective wavelengths,  $\lambda_1, \lambda_2$ , of the photons emitted in this process is :  
 (a)  $9/7$                       (b)  $7/5$                       (c)  $27/5$                       (d)  $20/7$
- One kg of water, at  $20^\circ\text{C}$ , is heated in an electric kettle whose heating element has a mean (temperature averaged) resistance of  $20\ \Omega$ . The rms voltage in the mains is 200 V. Ignoring heat loss from the kettle, time taken for water to evaporate fully, is close to : [Specific heat of water =  $4200\ \text{J/kg } ^\circ\text{C}$ ], Latent heat of water =  $2260\ \text{kJ/kg}$ ]  
 (a) 3 minutes                      (b) 22 minutes                      (c) 10 minutes                      (d) 16 minutes
- A tuning fork of frequency 480 Hz is used in an experiment for measuring speed of sound ( $v$ ) in air by resonance tube method. Resonance is observed to occur at two successive lengths of the air column,  $l_1 = 30\ \text{cm}$  and  $l_2 = 70\ \text{cm}$ . Then  $v$  is equal to :  
 (a)  $332\ \text{ms}^{-1}$                       (b)  $379\ \text{ms}^{-1}$                       (c)  $384\ \text{ms}^{-1}$                       (d)  $338\ \text{ms}^{-1}$
- Two sources of sound  $S_1$  and  $S_2$  produce sound waves of same frequency 660 Hz. A listener is moving from source  $S_1$  towards  $S_2$  with a constant speed  $u\ \text{m/s}$  and he hears 10 beats/s. The velocity of sound is 330 m/s. Then,  $u$  equals:  
 (a) 2.5 m/s                      (b) 15.0 m/s                      (c) 5.5 m/s                      (d) 10.0 m/s
- A particle is moving with speed  $v = b\sqrt{x}$  along positive x-axis. Calculate the speed of the particle at time  $t = \tau$  (assume that the particle is at origin at  $t = 0$ ).  
 (a)  $\frac{b^2\tau}{4}$                       (b)  $\frac{b^2\tau}{2}$                       (c)  $b^2\tau$                       (d)  $\frac{b^2\tau}{\sqrt{2}}$
- Consider an electron in a hydrogen atom, revolving in its second excited state (having radius  $4.65\ \text{\AA}$ ). The de-Broglie wavelength of this electron is :  
 (a)  $12.9\ \text{\AA}$                       (b)  $3.5\ \text{\AA}$                       (c)  $9.7\ \text{\AA}$                       (d)  $6.6\ \text{\AA}$
- A moving coil galvanometer, having a resistance  $G$ , produces full scale deflection when a current  $I_g$  flows through it. This galvanometer can be converted into (i) an ammeter of range 0 to  $I_0$  ( $I_0 > I_g$ ) by connecting a shunt resistance  $R_A$  to it and (ii) into a voltmeter of range 0 to  $V$  ( $V = GI_0$ ) by connecting a series resistance  $R_V$  to it. Then,  
 (a)  $R_A R_V = G^2 \left( \frac{I_g}{I_0 - I_g} \right)$  and  $\frac{R_A}{R_V} = \left( \frac{I_0 - I_g}{I_g} \right)^2$                       (b)  $R_A R_V = G^2$  and  $\frac{R_A}{R_V} = \left( \frac{I_g}{I_0 - I_g} \right)^2$   
 (c)  $R_A R_V = G^2$  and  $\frac{R_A}{R_V} = \frac{I_g}{(I_0 - I_g)}$                       (d)  $R_A R_V = G^2 \left( \frac{I_0 - I_g}{I_g} \right)$  and  $\frac{R_A}{R_V} = \left( \frac{I_g}{I_0 - I_g} \right)^2$
- The number density of molecules of a gas depends on their distance  $r$  from the origin as,  $n(r) = n_0 e^{-\alpha x^4}$ . Then the total number of molecules is proportional to :  
 (a)  $n_0 \alpha^{1/4}$                       (b)  $n_0 \alpha^{-3}$                       (c)  $n_0 \alpha^{-3/4}$                       (d)  $\sqrt{n_0} \alpha^{1/2}$

9. A smooth wire of length  $2\pi r$  is bent into a circle and kept in a vertical plane. A bead can slide smoothly on the wire. When the circle is rotating with angular speed  $\omega$  about the vertical diameter AB, as shown in figure, the bead is at rest with respect to the circular ring at position P as shown. Then the value of  $\omega^2$  is equal to :

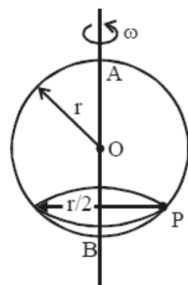

- (a)  $(g\sqrt{3})/r$       (b)  $\frac{\sqrt{3}g}{2r}$       (c)  $2g/r$       (d)  $2g/(r\sqrt{3})$
10. Find the magnetic field at point P due to a straight line segment AB of length 6 cm carrying a current of 5 A. (See figure)  
( $\mu_0 = 4\pi \times 10^{-7} \text{ N-A}^{-2}$ )

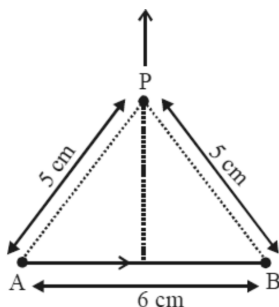

- (a)  $3.0 \times 10^{-5} \text{ T}$       (b)  $2.5 \times 10^{-5} \text{ T}$       (c)  $2.0 \times 10^{-5} \text{ T}$       (d)  $1.5 \times 10^{-5} \text{ T}$
11. A transparent cube of side  $d$ , made of a material of refractive index  $\mu_2$ , is immersed in a liquid of refractive index  $\mu_1$  ( $\mu_1 < \mu_2$ ). A ray is incident on the face AB at an angle  $\theta$  (shown in the figure). Total internal reflection takes place at point E on the face BC.

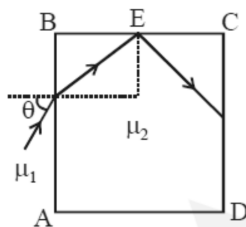

The  $\theta$  must satisfy :

- (a)  $\theta < \sin^{-1} \frac{\mu_1}{\mu_2}$       (b)  $\theta < \sin^{-1} \sqrt{\frac{\mu_2^2}{\mu_1^2} - 1}$       (c)  $\theta > \sin^{-1} \frac{\mu_1}{\mu_2}$       (d)  $\theta > \sin^{-1} \sqrt{\frac{\mu_2^2}{\mu_1^2} - 1}$
12. Let a total charge  $2Q$  be distributed in a sphere of radius  $R$ , with the charge density given by  $\rho(r) = kr$ , where  $r$  is the distance from the centre. Two charges A and B, of  $-Q$  each, are placed on diametrically opposite points, at equal distance,  $a$ , from the centre. If A and B do not experience any force, then :
- (a)  $a = \frac{3R}{2^{1/4}}$       (b)  $a = R/\sqrt{3}$       (c)  $a = 8^{-1/4}R$       (d)  $a = 2^{-1/4}R$
13. Two particles are projected from the same point with the same speed  $u$  such that they have the same range  $R$ , but different maximum heights,  $h_1$  and  $h_2$ . Which of the following is correct?
- (a)  $R^2 = 2 h_1 h_2$       (b)  $R^2 = 16 h_1 h_2$       (c)  $R^2 = 4 h_1 h_2$       (d)  $R^2 = h_1 h_2$

14. A spring whose unstretched length is  $l$  has a force constant  $k$ . The spring is cut into two pieces of unstretched lengths  $l_1$  and  $l_2$  where,  $l_1 = nl_2$  and  $n$  is an integer. The ratio  $k_1/k_2$  of the corresponding force constants,  $k_1$  and  $k_2$  will be :

(a)  $\frac{1}{n^2}$                       (b)  $n^2$                       (c)  $\frac{1}{n}$                       (d)  $n$

15. A block of mass 5 kg is (i) pushed in case (A) and (ii) pulled in case (B), by a force  $F = 20$  N, making an angle of  $30^\circ$  with the horizontal, as shown in the figures. The coefficient of friction between the block and floor is  $\mu = 0.2$ . The difference between the accelerations of the block, in case (B) and case (A) will be : ( $g = 10 \text{ ms}^{-2}$ )

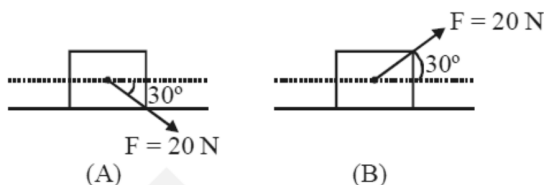

(a)  $0 \text{ ms}^{-2}$                       (b)  $0.8 \text{ ms}^{-2}$                       (c)  $0.4 \text{ ms}^{-2}$                       (d)  $3.2 \text{ ms}^{-2}$

16. Consider the LR circuit shown in the figure. If the switch  $S$  is closed at  $t = 0$  then the amount of charge that passes through the battery between  $t = 0$  and  $t = \frac{L}{R}$  is:

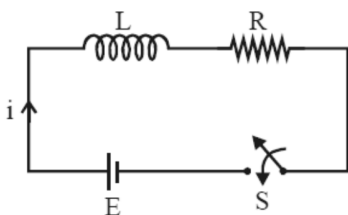

(a)  $\frac{EL}{7.3R^2}$                       (b)  $\frac{EL}{2.7R^2}$                       (c)  $\frac{7.3EL}{R^2}$                       (d)  $\frac{2.7EL}{R^2}$

17. A system of three polarizers  $P_1, P_2, P_3$  is set up such that the pass axis of  $P_3$  is crossed with respect to that of  $P_1$ . The pass axis of  $P_2$  is inclined at  $60^\circ$  to the pass axis of  $P_3$ . When a beam of unpolarized light of intensity  $I_0$  is incident on  $P_1$ , the intensity of light transmitted by the three polarizers is  $I$ . The ratio  $(I_0/I)$  equals (nearly) :

(a) 16.00                      (b) 1.80                      (c) 5.33                      (d) 10.67

18. Half lives of two radioactive nuclei A and B are 10 minutes and 20 minutes, respectively. If, initially a sample has equal number of nuclei, then after 60 minutes, the ratio of decayed numbers of nuclei A and B will be :

(a) 9 : 8                      (b) 1 : 8                      (c) 8 : 1                      (d) 3 : 8

19. A solid sphere, of radius  $R$  acquires a terminal velocity  $v_1$  when falling (due to gravity) through a viscous fluid having a coefficient of viscosity  $\eta$ . The sphere is broken into 27 identical solid spheres. If each of these spheres acquires a terminal velocity,  $v_2$ , when falling through the same fluid, the ratio  $(v_1/v_2)$  equals :

(a)  $1/27$                       (b)  $1/9$                       (c) 27                      (d) 9

20. The ratio of the weights of a body on the Earth's surface to that on the surface of a planet is 9 : 4. The mass of the planet is  $\frac{1}{9}$ th of that of the Earth. If 'R' is the radius of the Earth, what is the radius of the planet? (Take the planets to have the same mass density)

(a)  $\frac{R}{3}$                       (b)  $\frac{R}{2}$                       (c)  $\frac{R}{4}$                       (d)  $\frac{R}{9}$

21. Figure shown a DC voltage regulator circuit, with a Zener diode of breakdown voltage = 6V. If the unregulated input voltage varies between 10 V to 16 V, then what is the maximum Zener current ?

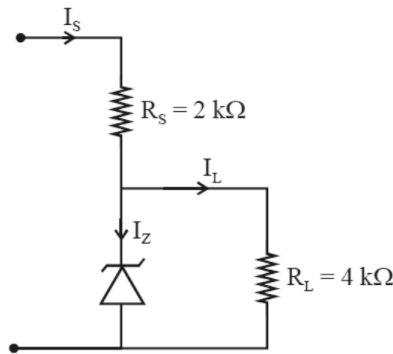

- (a) 2.5 mA                      (b) 3.5 mA                      (c) 7.5 mA                      (d) 1.5 mA
22. A Carnot engine has an efficiency of  $1/6$ . When the temperature of the sink is reduced by  $62^\circ\text{C}$ , its efficiency is doubled. The temperatures of the source and the sink are, respectively
- (a)  $124^\circ\text{C}$ ,  $62^\circ\text{C}$                       (b)  $37^\circ\text{C}$ ,  $99^\circ\text{C}$                       (c)  $62^\circ\text{C}$ ,  $124^\circ\text{C}$                       (d)  $99^\circ\text{C}$ ,  $37^\circ\text{C}$
23. A diatomic gas with rigid molecules does 10 J of work when expanded at constant pressure. What would be the heat energy absorbed by the gas, in this process?
- (a) 35 J                      (b) 40 J                      (c) 25 J                      (d) 30 J
24. A small speaker delivers 2 W of audio output. At what distance from the speaker will one detect 120 dB intensity sound? [Given reference intensity of sound as  $10^{-12}\text{W/m}^2$ ]
- (a) 10 cm                      (b) 30 cm                      (c) 40 cm                      (d) 20 cm
25. A uniform cylindrical rod of length  $L$  and radius  $r$ , is made from a material whose Young's modulus of Elasticity equals  $Y$ . When this rod is heated by temperature  $T$  and simultaneously subjected to a net longitudinal compressional force  $F$ , its length remains unchanged. The coefficient of volume expansion, of the material of the rod, is (nearly) equals to :
- (a)  $F/(3\pi r^2YT)$                       (b)  $3F/(\pi r^2YT)$                       (c)  $6F/(\pi r^2YT)$                       (d)  $9F/(\pi r^2YT)$
26. Three particles of masses 50 g, 100 g and 150 g are placed at the vertices of an equilateral triangle of side 1 m (as shown in the figure). The  $(x, y)$  coordinates of the centre of mass will be :

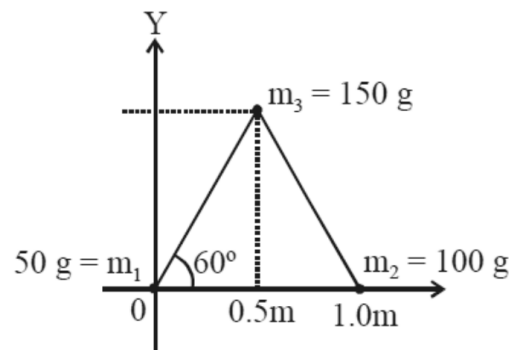

- (a)  $\left(\frac{7}{12}\text{ m}, \frac{\sqrt{3}}{8}\text{ m}\right)$                       (b)  $\left(\frac{\sqrt{3}}{4}\text{ m}, \frac{5}{12}\text{ m}\right)$                       (c)  $\left(\frac{7}{12}\text{ m}, \frac{\sqrt{3}}{4}\text{ m}\right)$                       (d)  $\left(\frac{\sqrt{3}}{8}\text{ m}, \frac{7}{12}\text{ m}\right)$

27. An electron, moving along the x-axis with an initial energy of 100 eV, enters a region of magnetic field  $\vec{B} = (1.5 \times 10^{-3} \text{T})\hat{k}$  at S (See figure). The field extends between  $x = 0$  and  $x = 2$  cm. The electron is detected at the point Q on a screen placed 8 cm away from the point S. The distance  $d$  between P and Q (on the screen) is : (electron's charge =  $1.6 \times 10^{-19}$  C, mass of electron =  $9.1 \times 10^{-31}$  kg)

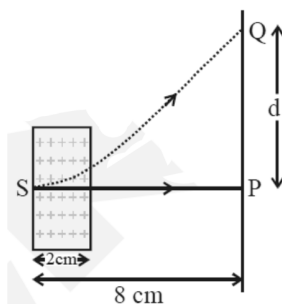

- (a) 12.87 cm      (b) 1.22 cm      (c) 11.65 cm      (d) 2.25 cm
28. A plane electromagnetic wave having a frequency  $\nu = 23.9$  GHz propagates along the positive z-direction in free space. The peak value of the electric field is 60 V/m. Which among the following is the acceptable magnetic field component in the electromagnetic wave?
- (a)  $\vec{B} = 2 \times 10^7 \sin(0.5 \times 10^3 z + 1.5 \times 10^{11} t) \hat{i}$   
 (b)  $\vec{B} = 2 \times 10^{-7} \sin(1.5 \times 10^2 x + 0.5 \times 10^{11} t) \hat{j}$   
 (c)  $\vec{B} = 2 \times 10^{-7} \sin(0.5 \times 10^3 z - 1.5 \times 10^{11} t) \hat{i}$   
 (d)  $\vec{B} = 60 \sin(0.5 \times 10^3 x + 1.5 \times 10^{11} t) \hat{k}$
29. In an amplitude modulator circuit, the carrier wave is given by,  $C(t) = 4 \sin(20000 \pi t)$  while modulating signal is given by,  $m(t) = 2 \sin(200 \pi t)$ . The values of modulation index and lower side band frequency are :
- (a) 0.5 and 9 kHz      (b) 0.5 and 10 kHz      (c) 0.3 and 9 kHz      (d) 0.4 and 10 kHz
30. In the given circuit, the charge on  $4 \mu\text{F}$  capacitor will be :

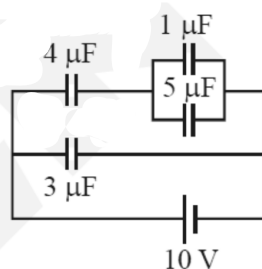

- (a)  $5.4 \mu\text{C}$       (b)  $24 \mu\text{C}$       (c)  $13.4 \mu\text{C}$       (d)  $9.6 \mu\text{C}$

## Chemistry

31. The molar solubility of  $\text{Cd}(\text{OH})_2$  is  $1.84 \times 10^{-5}$  M in water. The expected solubility of  $\text{Cd}(\text{OH})_2$  in a buffer solution of  $\text{pH} = 12$  is :
- (a)  $6.23 \times 10^{-11}$  M      (b)  $1.84 \times 10^{-9}$  M      (c)  $\frac{2.49}{1.84} \times 10^{-9}$  M      (d)  $2.49 \times 10^{-10}$  M
32. The correct statement is :
- (a) leaching of bauxite using concentrated NaOH solution gives sodium aluminate and sodium silicate  
 (b) the blistered appearance of copper during the metallurgical process is due to the evolution of  $\text{CO}_2$   
 (c) pig iron is obtained from cast iron  
 (d) the Hall-Heroult process is used for the production of aluminium and iron

33. Which one of the following is likely to give a precipitate with  $\text{AgNO}_3$  solution?  
 (a)  $(\text{CH}_3)_3\text{CCl}$  (b)  $\text{CHCl}_3$  (c)  $\text{CH}_2=\text{CH}-\text{Cl}$  (d)  $\text{CCl}_4$
34. The compound used in the treatment of lead poisoning is :  
 (a) EDTA (b) Cis-platin (c) D-penicillamine (d) desferrioxime B
35. A solution is prepared by dissolving 0.6 g of urea (molar mass =  $60 \text{ g mol}^{-1}$ ) and 1.8 g of glucose (molar mass =  $180 \text{ g mol}^{-1}$ ) in 100 mL of water at  $27^\circ\text{C}$ . The osmotic pressure of the solution is : ( $R = 0.08206 \text{ L atm K}^{-1} \text{ mol}^{-1}$ )  
 (a) 4.92 atm (b) 1.64 atm (c) 2.46 atm (d) 8.2 atm
36. Consider the following reactions:

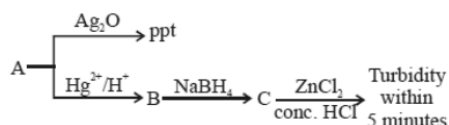

'A' is :

- (a)  $\text{CH}\equiv\text{CH}$  (b)  $\text{CH}_3-\text{C}\equiv\text{CH}$  (c)  $\text{CH}_2=\text{CH}_2$  (d)  $\text{CH}_3-\text{C}\equiv\text{C}-\text{CH}_3$
37. What will be the major product when m-cresol is reacted with propargyl bromide ( $\text{HC}\equiv\text{C}-\text{CH}_2\text{Br}$ ) in present of  $\text{K}_2\text{CO}_3$  in acetone

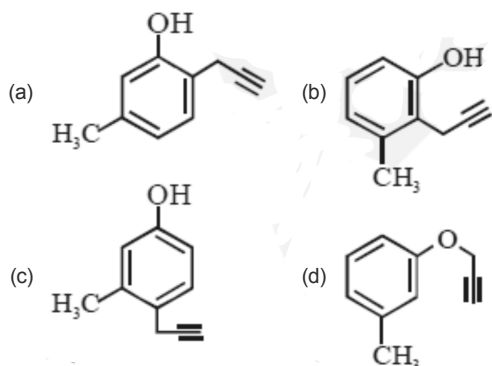

38. The INCORRECT match in the following is :  
 (a)  $\Delta G^\circ < 0, K < 1$  (b)  $\Delta G^\circ = 0, K = 1$  (c)  $\Delta G^\circ > 0, K < 1$  (d)  $\Delta G^\circ < 0, K > 1$
39. The correct name of the following polymer is:

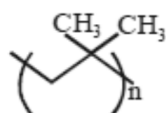

- (a) Polyisoprene (b) Polytert-butylene (c) Polyisobutane (d) Polyisobutylene
40. Among the following, the energy of 2s orbital is lowest in :  
 (a) K (b) Na (c) Li (d) H
41. The primary pollutant that leads to photochemical smog is :  
 (a) sulphur dioxide (b) acrolein (c) ozone (d) nitrogen oxides
42. An 'Assertion' and a 'Reason' are given below. Choose the correct answer from the following options.  
**Assertion (a)** : Vinyl halides do not undergo nucleophilic substitution easily.  
**Reason (R)** : Even though the intermediate carbocation is stabilized by loosely held  $\pi$ -electrons, the cleavage is difficult because of strong bonding.  
 (a) Both (A) and (R) are wrong statements  
 (b) Both (A) and (R) are correct statements and (R) is the correct explanation of (A)  
 (c) Both (A) and (R) are correct statements but (R) is not the correct explanation of (A)  
 (d) (A) is a correct statement but (R) is a wrong statement.

43. The coordination numbers of Co and Al in  $[\text{Co}(\text{Cl})(\text{en})_2]\text{Cl}$  and  $\text{K}_3[\text{Al}(\text{C}_2\text{O}_4)_3]$ , respectively, are : (en=ethane-1,2-diamine)  
 (a) 3 and 3                      (b) 6 and 6                      (c) 5 and 6                      (d) 5 and 3
44. The IUPAC name of the following compound is :

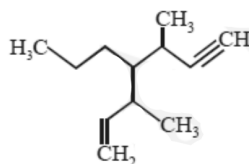

- (a) 3,5-dimethyl-4-propylhept-6-en-1-yne  
 (b) 3-methyl-4-(3-methylprop-1-enyl)-1-heptyne  
 (c) 3-methyl-4-(1-methylprop-2-ynyl)-1-heptene  
 (d) 3, 5-dimethyl-4-propylhept-1-en-6-yne
45. Among the following, the INCORRECT statement about colloids is :  
 (a) They can scatter light  
 (b) They are larger than small molecules and have high molar mass  
 (c) The range of diameters of colloidal particles is between 1 and 1000 nm  
 (d) The osmotic pressure of a colloidal solution is of higher order than the true solution at the same concentration
46. In comparison to boron, beryllium has :  
 (a) lesser nuclear charge and greater first ionisation enthalpy  
 (b) lesser nuclear charge and lesser first ionisation enthalpy  
 (c) greater nuclear charge and greater first ionisation enthalpy  
 (d) greater nuclear charge and lesser first ionisation enthalpy
47. In the following skew conformation of ethane,  $\text{H}'\text{-C-C-H}''$  dihedral angle is :

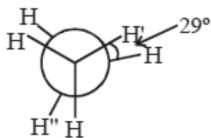

- (a)  $120^\circ$                       (b)  $58^\circ$                       (c)  $149^\circ$                       (d)  $151^\circ$
48.  $\text{NO}_2$  required for a reaction is produced by the decomposition of  $\text{N}_2\text{O}_5$  in  $\text{CCl}_4$  as per the equation  $2\text{N}_2\text{O}_5(\text{g}) \rightarrow 4\text{NO}_2(\text{g}) + \text{O}_2(\text{g})$ . The initial concentration of  $\text{N}_2\text{O}_5$  is  $3.00 \text{ mol L}^{-1}$  and it is  $2.75 \text{ mol L}^{-1}$  after 30 minutes. The rate of formation of  $\text{NO}_2$  is :  
 (a)  $2.083 \times 10^{-3} \text{ mol L}^{-1} \text{ min}^{-1}$                       (b)  $4.167 \times 10^{-3} \text{ mol L}^{-1} \text{ min}^{-1}$   
 (c)  $8.333 \times 10^{-3} \text{ mol L}^{-1} \text{ min}^{-1}$                       (d)  $1.667 \times 10^{-2} \text{ mol L}^{-1} \text{ min}^{-1}$
49. Thermal decomposition of a Mn compound (X) at 513 K results in compound Y,  $\text{MnO}_2$  and a gaseous product.  $\text{MnO}_2$  reacts with  $\text{NaCl}$  and concentrated  $\text{H}_2\text{SO}_4$  to give a pungent gas Z. X, Y and Z, respectively.  
 (a)  $\text{K}_2\text{MnO}_4$ ,  $\text{KMnO}_4$  and  $\text{SO}_2$                       (b)  $\text{K}_2\text{MnO}_4$ ,  $\text{KMnO}_4$  and  $\text{Cl}_2$   
 (c)  $\text{K}_3\text{MnO}_4$ ,  $\text{K}_2\text{MnO}_4$  and  $\text{Cl}_2$                       (d)  $\text{KMnO}_4$ ,  $\text{K}_2\text{MnO}_4$  and  $\text{Cl}_2$
50. 25 g of an unknown hydrocarbon upon burning produces 88 g of  $\text{CO}_2$  and 9 g of  $\text{H}_2\text{O}$ . This unknown hydrocarbon contains.  
 (a) 20g of carbon and 5 g of hydrogen                      (b) 24g of carbon and 1 g of hydrogen  
 (c) 18g of carbon and 7 g of hydrogen                      (d) 22g of carbon and 3 g of hydrogen
51. Which of the given statements is INCORRECT about glycogen?  
 (a) It is a straight chain polymer similar to amylose  
 (b) Only  $\alpha$ -linkages are present in the molecule  
 (c) It is present in animal cells  
 (d) It is present in some yeast and fungi

52. The C–C bond length is maximum in  
 (a) graphite (b)  $C_{70}$  (c) diamond (d)  $C_{60}$
53. The temporary hardness of a water sample is due to compound X. Boiling this sample converts X to compound Y. X and Y, respectively, are :  
 (a)  $Ca(HCO_3)_2$  and CaO (b)  $Mg(HCO_3)_2$  and  $MgCO_3$   
 (c)  $Mg(HCO_3)_2$  and  $Mg(OH)_2$  (d)  $Ca(HCO_3)_2$  and  $Ca(OH)_2$
54. The ratio of number of atoms present in a simple cubic, body centered cubic and face centered cubic structure are, respectively :  
 (a) 1 : 2 : 4 (b) 8 : 1 : 6 (c) 4 : 2 : 1 (d) 4 : 2 : 3
55. Heating of 2-chloro-1-phenylbutane with EtOK/EtOH gives X as the major product. Reaction of X with  $Hg(OAc)_2/H_2O$  followed by  $NaBH_4$  gives Y as the major product. Y is :

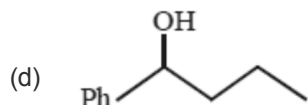
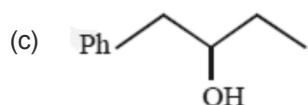
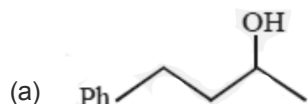

56. In which one of the following equilibria,  $K_p \neq K_c$ ?  
 (a)  $NO_2(g) + SO_2(g) \rightleftharpoons NO(g) + SO_3(g)$   
 (b)  $2 HI(g) \rightleftharpoons H_2(g) + I_2(g)$   
 (c)  $2NO(g) \rightleftharpoons N_2(g) + O_2(g)$   
 (d)  $2C(s) + O_2(g) \rightleftharpoons 2CO(g)$

57. Benzene diazonium chloride on reaction with aniline in the presence of dilute hydrochloric acid gives :

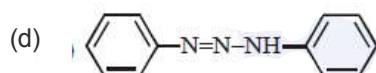
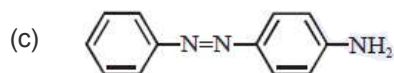
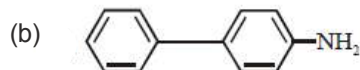
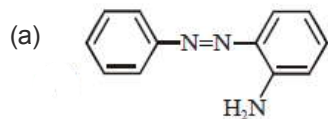



58. The decreasing order of electrical conductivity of the following aqueous solutions is :  
 0.1 M Formic acid (A),  
 0.1 M Acetic acid (B)  
 0.1 M Benzoic acid (C)  
 (a)  $C > B > A$       (c)  $A > B > C$       (b)  $A > C > B$       (d)  $C > A > B$
59. The INCORRECT statement is :  
 (a) Lithium is least reactive with water among the alkali metals.  
 (b) LiCl crystallises from aqueous solution as  $\text{LiCl} \cdot 2\text{H}_2\text{O}$ .  
 (c) Lithium is the strongest reducing agent among the alkali metals.  
 (d)  $\text{LiNO}_3$  decomposes on heating to give  $\text{LiNO}_2$  and  $\text{O}_2$ .
60. The pair that has similar atomic radii is :  
 (a) Sc and Ni      (b) Ti and HF      (c) Mo and W      (d) Mn and Re

## Mathematics

61. Let A, B and C be sets such that  $\phi \neq A \cap B \subseteq C$ . Then which of the following statements is not true?  
 (a) If  $(A - C) \subseteq B, A \subseteq B$       (b)  $(C \cup A) \cap (C \cup B) = C$   
 (c) If  $(A - B) \subseteq C$ , then  $A \subseteq C$       (d)  $B \cap C \neq \phi$
62. If  ${}^{20}\text{C}_1 + (2^2) {}^{20}\text{C}_2 + (3^2) {}^{20}\text{C}_3 + \dots + (20^2) {}^{20}\text{C}_{20} = A(2^\beta)$ , then the ordered pair (A,  $\beta$ ) is equal to:  
 (a) (420, 18)      (b) (380, 19)      (c) (380, 18)      (d) (420, 19)
63. A straight line L at a distance of 4 units from the origin makes positive intercepts on the coordinate axes and the perpendicular from the origin to this line makes an angle of  $60^\circ$  with the line  $x + y = 0$ . Then an equation of the line L is :  
 (a)  $(\sqrt{3} + 1)x + (\sqrt{3} - 1)y = 8\sqrt{2}$       (b)  $(\sqrt{3} - 1)x + (\sqrt{3} + 1)y = 8\sqrt{2}$   
 (c)  $\sqrt{3}x + y = 8$       (d)  $x + \sqrt{3}y = 8$
64. A value of  $\theta \in (0, \pi/3)$ , for which  $\begin{vmatrix} 1 + \cos^2 \theta & \sin^2 \theta & 4 \cos 6\theta \\ \cos^2 \theta & 1 + \sin^2 \theta & 4 \cos 6\theta \\ \cos^2 \theta & \sin^2 \theta & 1 + 4 \cos 6\theta \end{vmatrix} = 0$ , is:  
 (a)  $\frac{7\pi}{24}$       (b)  $\frac{\pi}{18}$       (c)  $\frac{\pi}{9}$       (d)  $\frac{7\pi}{36}$
65. If  $[x]$  denotes the greatest integer  $\leq x$ , then the system of linear equations  $[\sin \theta] x + [-\cos \theta] y = 0$   $[\cot \theta] x + y = 0$   
 (a) have infinitely many solutions if  $\theta \in \left(\frac{\pi}{2}, \frac{2\pi}{3}\right) \cup \left(\pi, \frac{7\pi}{6}\right)$   
 (b) have infinitely many solutions if  $\theta \in \left(\frac{\pi}{2}, \frac{2\pi}{3}\right)$  and has a unique solution if  $\theta \in \left(\pi, \frac{7\pi}{6}\right)$   
 (c) has a unique solution if  $\theta \in \left(\frac{\pi}{2}, \frac{2\pi}{3}\right)$  and have infinitely many solutions if  $\theta \in \left(\pi, \frac{7\pi}{6}\right)$   
 (d) has a unique solution if  $\theta \in \left(\frac{\pi}{2}, \frac{2\pi}{3}\right) \cup \left(\pi, \frac{7\pi}{6}\right)$
66.  $\lim_{x \rightarrow 0} \frac{x + 2 \sin x}{\sqrt{x^2 - 2 \sin x + 1} - \sqrt{\sin^2 x - x + 1}}$  is :  
 (a) 3      (b) 2      (c) 6      (d) 1

67. If  $a_1, a_2, a_3, \dots$  are in A.P. such that  $a_1 + a_7 + a_{16} = 40$ , then the sum of the first 15 terms of this A.P. is :  
 (a) 200 (b) 280 (c) 120 (d) 150
68. The length of the perpendicular drawn from the point  $(2, 1, 4)$  to the plane containing the lines  $\vec{r} = (\hat{i} + \hat{j}) + \lambda(\hat{i} + 2\hat{j} - \hat{k})$  and  $\vec{r} = (\hat{i} + \hat{j}) + \mu(-\hat{i} + \hat{j} - 2\hat{k})$  is:  
 (a)  $\sqrt{3}$  (b)  $\frac{1}{\sqrt{3}}$  (c)  $\frac{1}{3}$  (d) 3
69. If  $\alpha, \beta$  and  $\gamma$  are three consecutive terms of a non-constant G.P. such that the equations  $\alpha x^2 + 2\beta x + \gamma = 0$  and  $x^2 + x - 1 = 0$  have a common root, then  $\alpha(\beta + \gamma)$  is equal to :  
 (a)  $\beta\gamma$  (b) 0 (c)  $\alpha\gamma$  (d)  $\alpha\beta$
70. The term independent of  $x$  in the expansion of  $\left(\frac{1}{60} - \frac{x^8}{81}\right) \cdot \left(2x^2 - \frac{3}{x^2}\right)^6$  is equal to :  
 (a) 316 (b) -108 (c) -72 (d) -36
71. Let  $\alpha \in \mathbb{R}$  and the three vectors  $\vec{a} = \alpha\hat{i} + \hat{j} + 3\hat{k}$ ,  $\vec{b} = 2\hat{i} + \hat{j} - \alpha\hat{k}$  and  $\vec{c} = \alpha\hat{i} - 2\hat{j} + 3\hat{k}$ . Then the set  $S = \{\alpha : \vec{a}, \vec{b} \text{ and } \vec{c} \text{ are coplanar}\}$   
 (a) is singleton  
 (b) Contains exactly two numbers only one of which is positive  
 (c) Contains exactly two positive numbers  
 (d) is empty
72. A value of  $\alpha$  such that  $\int_{\alpha}^{\alpha+1} \frac{dx}{(x+\alpha)(x+\alpha+1)} = \log_e\left(\frac{9}{8}\right)$  is:  
 (a)  $\frac{1}{2}$  (b) 2 (c)  $-\frac{1}{2}$  (d) -2
73. A triangle has a vertex at  $(1, 2)$  and the mid points of the two sides through it are  $(-1, 1)$  and  $(2, 3)$ . Then the centroid of this triangle is :  
 (a)  $\left(\frac{1}{3}, 1\right)$  (b)  $\left(\frac{1}{3}, 2\right)$  (c)  $\left(1, \frac{7}{3}\right)$  (d)  $\left(\frac{1}{3}, \frac{5}{3}\right)$
74. Let  $\alpha \in (0, \pi/2)$  be fixed. If the integral  $\int \frac{\tan x + \tan \alpha}{\tan x - \tan \alpha} dx = A(x) \cos 2\alpha + B(x) \sin 2\alpha + C$ , where  $C$  is a constant of integration, then the functions  $A(x)$  and  $B(x)$  are respectively:  
 (a)  $x - \alpha$  and  $\log_e|\cos(x - \alpha)|$  (b)  $x + \alpha$  and  $\log_e|\sin(x - \alpha)|$   
 (c)  $x - \alpha$  and  $\log_e|\sin(x - \alpha)|$  (d)  $x + \alpha$  and  $\log_e|\sin(x + \alpha)|$
75. A circle touching the  $x$ -axis at  $(3, 0)$  and making an intercept of length 8 on the  $y$ -axis passes through the point :  
 (a)  $(3, 10)$  (b)  $(2, 3)$  (c)  $(1, 5)$  (d)  $(3, 5)$
76. For an initial screening of an admission test, a candidate is given fifty problems to solve. If the probability that the candidate can solve any problem is  $\frac{4}{5}$ , then the probability that he is unable to solve less than two problems is:  
 (a)  $\frac{316}{25}\left(\frac{4}{5}\right)^{48}$  (b)  $\frac{54}{5}\left(\frac{4}{5}\right)^{49}$  (c)  $\frac{164}{25}\left(\frac{1}{5}\right)^{48}$  (d)  $\frac{201}{5}\left(\frac{1}{5}\right)^{49}$

77. The derivative of  $\tan^{-1}\left(\frac{\sin x - \cos x}{\sin x + \cos x}\right)$  with respect to  $\frac{x}{2}$ , where  $\left(x \in \left(0, \frac{\pi}{2}\right)\right)$  is:
- (a)  $\frac{1}{2}$                       (b)  $\frac{2}{3}$                       (c) 1                      (d) 2
78. Let S be the set of all  $\alpha \in \mathbb{R}$  such that the equation,  $\cos 2x + \alpha \sin x = 2\alpha - 7$  has a solution. Then S is equal to :
- (a) [2, 6]                      (b) [3,7]                      (c)  $\mathbb{R}$                       (d) [1,4]
79. The tangents to the curve  $y = (x - 2)^2 - 1$  at its points of intersection with the line  $x - y = 3$ , intersect at the point :
- (a)  $\left(-\frac{5}{2}, -1\right)$                       (b)  $\left(-\frac{5}{2}, 1\right)$                       (c)  $\left(\frac{5}{2}, -1\right)$                       (d)  $\left(\frac{5}{2}, 1\right)$
80. A group of students comprises of 5 boys and n girls. If the number of ways, in which a team of 3 students can randomly be selected from this group such that there is at least one boy and at least one girl in each team, is 1750, then n is equal to :
- (a) 25                      (b) 28                      (c) 27                      (d) 24
81. The equation of a common tangent to the curves,  $y^2 = 16x$  and  $xy = -4$  is :
- (a)  $x + y + 4 = 0$                       (b)  $x - 2y + 16 = 0$                       (c)  $2x - y + 2 = 0$                       (d)  $x - y + 4 = 0$
82. Let  $z \in \mathbb{C}$  with  $\text{Im}(z) = 10$  and it satisfies  $\frac{2z - n}{2z + n} = 2i - 1$  for some natural number n. then :
- (a)  $n = 20$  and  $\text{Re}(z) = -10$                       (b)  $n = 20$  and  $\text{Re}(z) = 10$   
(c)  $n = 40$  and  $\text{Re}(z) = -10$                       (d)  $n = 40$  and  $\text{Re}(z) = 10$
83. The general solution of the differential equation  $(y^2 - x^3) dx - xy dy = 0$  ( $x \neq 0$ ) is : (where c is a constant of integration)
- (a)  $y^2 + 2x^3 + cx^2 = 0$                       (b)  $y^2 + 2x^2 + cx^3 = 0$   
(c)  $y^2 - 2x^3 + cx^2 = 0$                       (d)  $y^2 - 2x^2 + cx^3 = 0$
84. A person throws two fair dice. He wins Rs. 15 for throwing a doublet (same numbers on the two dice), wins Rs.12 when the throw results in the sum of 9, and loses Rs. 6 for any other outcome on the throw. Then the expected gain/loss (in Rs.) of the person is :
- (a) 2 gain                      (b)  $\frac{1}{2}$  loss                      (c)  $\frac{1}{4}$  loss                      (d)  $\frac{1}{2}$  gain
85. Let  $f(x) = 5 - |x - 2|$  and  $g(x) = |x + 1|$ ,  $x \in \mathbb{R}$ . If  $f(x)$  attains maximum value at  $\alpha$  and  $g(x)$  attains minimum value at  $\beta$ , then  $\lim_{x \rightarrow \alpha\beta} \frac{(x-1)(x^2 - 5x + 6)}{x^2 - 6x + 8}$  is equal to :
- (a)  $1/2$                       (b)  $-3/2$                       (c)  $3/2$                       (d)  $-1/2$
86. The angle of elevation of the top of vertical tower standing on a horizontal plane is observed to be  $45^\circ$  from a point A on the plane. Let B be the point 30 m vertically above the point A. If the angle of elevation of the top of the tower from B be  $30^\circ$ , then the distance (in m) of the foot of the tower from the point A is:
- (a)  $15(3 - \sqrt{3})$                       (b)  $15(3 + \sqrt{3})$                       (c)  $15(1 + \sqrt{3})$                       (d)  $15(5 - \sqrt{3})$
87. The Boolean expression  $\sim (p \Rightarrow (\sim q))$  is equivalent to :
- (a)  $(\sim p) \Rightarrow q$                       (b)  $p \vee q$                       (c)  $q \Rightarrow \sim p$                       (d)  $p \wedge q$

88. A plane which bisects the angle between the two given planes  $2x - y + 2z - 4 = 0$  and  $x + 2y + 2z - 2 = 0$ , passes through the point:  
 (a)  $(2, 4, 1)$                       (b)  $(2, -4, 1)$                       (c)  $(1, 4, -1)$                       (d)  $(1, -4, 1)$
89. If the area (in sq. units) bounded by the parabola  $y^2 = 4\lambda x$  and the line  $y = \lambda x, \lambda > 0$ , is  $\frac{1}{9}$ , then  $\lambda$  is equal to:  
 (a) 24                                      (b) 48                                      (c)  $4\sqrt{3}$                                       (d)  $2\sqrt{6}$
90. An ellipse, with foci at  $(0, 2)$  and  $(0, -2)$  and minor axis of length 4, passes through which of the following points?  
 (a)  $(1, 2\sqrt{2})$                       (b)  $(2, \sqrt{2})$                                       (c)  $(2, 2\sqrt{2})$                                       (d)  $(\sqrt{2}, 2)$

**PCM Answers**

1	d	11	b	21	b	31	d	41	d	51	a	61	a	71	d	81	d
2	b	12	c	22	b	32	a	42	d	52	c	62	a	72	d	82	c
3	c	13	b	23	a	33	a	43	c	53	c	63	b	73	b	83	a
4	a	14	c	24	c	34	a	44	d	54	a	64	c	74	c	84	b
5	b	15	b	25	b	35	a	45	d	55	d	65	b	75	a	85	a
6	c	16	b	26	c	36	b	46	a	56	d	66	b	76	b	86	b
7	b	17	d	27	a	37	d	47	c	57	c	67	a	77	d	87	d
8	c	18	a	28	c	38	a	48	d	58	c	68	a	78	a	88	b
9	d	19	d	29	a	39	d	49	d	59	d	69	a	79	c	89	a
10	d	20	b	30	b	40	a	50	b	60	c	70	d	80	a	90	d