

JEE (Advanced) Examination-2019
(Held on Monday 27th May, 2019)
Paper-1

PART-1 : PHYSICS

SECTION-1 : (Maximum Marks : 12)

- This section contains **FOUR (04)** questions.
- Each question has **FOUR** options. **ONLY ONE** of these four options is the correct answer.
- For each question, choose the option corresponding to the correct answer.
- Answer to each question will be evaluated according to the following marking scheme :
Full Marks : +3 If **ONLY** the correct option is chosen.
Zero Marks : 0 If none of the options is chosen (i.e. the question is unanswered)
Negative Marks : -1 In all other cases

1. A current carrying wire heats a metal rod. The wire provides a constant power (P) to the rod. The metal rod is enclosed in an insulated container. It is observed that the temperature (T) in the metal rod changes with time (t) as :

$$T(t) = T_0(1 + \beta t^{1/4})$$

where β is a constant with appropriate dimension while T_0 is a constant with dimension of temperature. The heat capacity of the metal is :

- (a) $\frac{4P(T(t) - T_0)^3}{\beta^4 T_0^4}$ (b) $\frac{4P(T(t) - T_0)}{\beta^4 T_0^2}$ (c) $\frac{4P(T(t) - T_0)^4}{\beta^4 T_0^5}$ (d) $\frac{4P(T(t) - T_0)^2}{\beta^4 T_0^3}$

Ans. (a)

2. A thin spherical insulating shell of radius R carries a uniformly distributed charge such that the potential at its surface is V_0 . A hole with a small area $\alpha 4\pi R^2$ ($\alpha \ll 1$) is made on the shell without affecting the rest of the shell. Which one of the following statements is correct ?

- (a) The ratio of the potential at the center of the shell to that of the point at $\frac{1}{2}$ from center towards the hole will be $\frac{1-\alpha}{1-2\alpha}$.
- (b) The magnitude of electric field at the center of the shell is reduced by $\frac{\alpha V_0}{2R}$
- (c) The magnitude of electric field at a point, located on a line passing through the hole and shell's center on a distance 2R from the center of the spherical shell will be reduced by $\frac{\alpha V_0}{2R}$
- (d) The potential at the center of the shell is reduced by $2\alpha V_0$.

Ans. (a)

3. Consider a spherical gaseous cloud of mass density $\rho(r)$ in free space where r is the radial distance from its center. The gaseous cloud is made of particles of equal mass m moving in circular orbits about the common center with the same kinetic energy K. The force acting on the particles is their mutual gravitational force. If $\rho(r)$ is constant in time, the particle number density $n(r) = \rho(r)/m$ is : [G is universal gravitational constant]

- (a) $\frac{K}{\pi r^2 m^2 G}$ (b) $\frac{K}{6\pi r^2 m^2 G}$ (c) $\frac{3K}{\pi r^2 m^2 G}$ (d) $\frac{K}{2\pi r^2 m^2 G}$

Ans. (d)

4. In a radioactive sample, ${}^{40}_{19}\text{K}$ nuclei either decay into stable ${}^{40}_{20}\text{Ca}$ nuclei with decay constant 4.5×10^{-10} per year or into stable ${}^{40}_{18}\text{Ar}$ nuclei with decay constant 0.5×10^{-10} per year. Given that in this sample all the stable ${}^{40}_{20}\text{Ca}$ and ${}^{40}_{18}\text{Ar}$ nuclei are produced by the ${}^{40}_{19}\text{K}$ nuclei only. In time $t \times 10^9$ years, if the ratio of the sum of stable ${}^{40}_{20}\text{Ca}$ and ${}^{40}_{18}\text{Ar}$ nuclei to the radioactive ${}^{40}_{19}\text{K}$ nuclei is 99, the value of t will be : [Given $\ln 10 = 2.3$]
- (a) 9.2 (b) 1.15 (c) 4.6 (d) 2.3

Ans. (a)

SECTION-2 : (Maximum Marks: 32)

- This section contains **EIGHT (08)** questions.
- Each question has **FOUR** options. **ONE OR MORE THAN ONE** of these four option(s) is (are) correct answer(s).
- For each question, choose the option(s) corresponding to (all) the correct answer(s)
- Answer to each question will be evaluated according to the following marking scheme:
Full Marks : +4 If only (all) the correct option(s) is (are) chosen.
Partial Marks : +3 If all the four options are correct but **ONLY** three options are chosen.
Partial Marks : +2 If three or more options are correct but **ONLY** two options are chosen and both of which are correct.
Partial Marks : +1 If two or more options are correct but **ONLY** one option is chosen and it is a correct option.
Zero Marks : 0 If none of the options is chosen (i.e. the question is unanswered).
Negative Marks : -1 In all other cases.
- For example, in a question, if (A), (B) and (D) are the **ONLY** three options corresponding to correct answers, then
 choosing **ONLY** (A), (B) and (D) will get +4 marks;
 choosing **ONLY** (A) and (B) will get +2 marks;
 choosing **ONLY** (A) and (D) will get +2 marks;
 choosing **ONLY** (B) and (D) will get +2 marks;
 choosing **ONLY** (A) will get +1 marks;
 choosing **ONLY** (B) will get +1 marks;
 choosing **ONLY** (D) will get +1 marks;
 choosing no option (i.e. the question is unanswered) will get 0 marks; and
 choosing any other combination of options will get -1 mark.

1. One mole of a monoatomic ideal gas goes through a thermodynamic cycle, as shown in the volume versus temperature (V-T) diagram. The correct statement(s) is/are : [R is the gas constant]

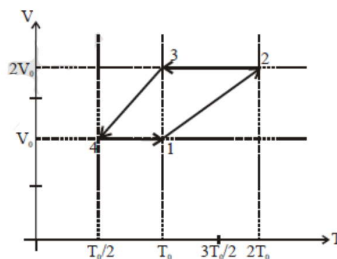

- (a) Work done in this thermodynamic cycle ($1 \rightarrow 2 \rightarrow 3 \rightarrow 4 \rightarrow 1$) is $|W| = \frac{1}{2}RT_0$
- (b) The ratio of heat transfer during processes $1 \rightarrow 2$ and $2 \rightarrow 3$ is $\left| \frac{Q_{1 \rightarrow 2}}{Q_{2 \rightarrow 3}} \right| = \frac{5}{3}$
- (c) The above thermodynamic cycle exhibits only isochoric and adiabatic processes.
- (d) The ratio of heat transfer during processes $1 \rightarrow 2$ and $3 \rightarrow 4$ is $\left| \frac{Q_{1 \rightarrow 2}}{Q_{3 \rightarrow 4}} \right| = \frac{1}{2}$.

Ans. (a, b)

2. In the circuit shown, initially there is no charge on capacitors and keys S_1 and S_2 are open. The values of the capacitors are $C_1 = 10 \mu\text{F}$, $C_2 = 30 \mu\text{F}$ and $C_3 = C_4 = 80 \mu\text{F}$.

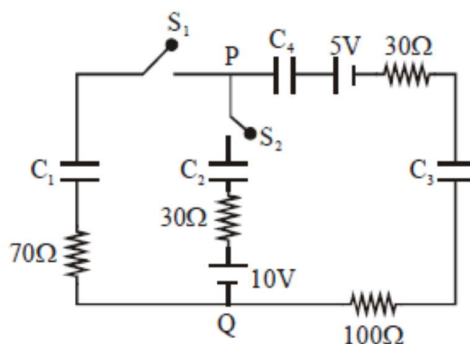

Which of the statement(s) is/are correct?

- The keys S_1 is kept closed for long time such that capacitors are fully charged. Now key S_2 is closed, at this time, the instantaneous current across 30Ω resistor (between points P and Q) will be 0.2 A (round off to 1^{st} decimal place).
- If key S_1 is kept closed for long time such that capacitors are fully charged, the voltage difference between points P and Q will be 10 V .
- At time $t = 0$, the key S_1 is closed, the instantaneous current in the closed circuit will be 25 mA .
- If key S_1 is kept closed for long time such that capacitors are fully charged, the voltage across the capacitors C_1 will be 4 V .

Ans. (c, d)

3. A thin convex lens is made of two materials with refractive indices n_1 and n_2 , as shown in figure. The radius of curvature of the left and right spherical surfaces are equal. f is the focal length of the lens when $n_1 = n_2 = n$. The focal length is $f + \Delta f$ when $n_1 = n$ and $n_2 = n + \Delta n$. Assuming $\Delta n \ll (n - 1)$ and $1 < n < 2$, the correct statement(s) is/are :

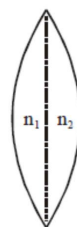

- The relation between $\frac{\Delta f}{f}$ and $\frac{\Delta n}{n}$ remains unchanged if both the convex surfaces are replaced by concave surfaces of the same radius of curvature.
- $\left| \frac{\Delta f}{f} \right| < \left| \frac{\Delta n}{n} \right|$
- For $n = 1.5$, $\Delta n = 10^{-3}$ and $f = 20 \text{ cm}$, the value of $|\Delta f|$ will be 0.02 cm (round off to 2^{nd} decimal place)
- If $\frac{\Delta n}{n} < 0$ then $\frac{\Delta f}{f} > 0$

Ans. (a, c, d)

4. Let us consider a system of units in which mass and angular momentum are dimensionless. If length has dimension of L , which of the following statement (s) is/are correct?
- (a) The dimension of force is L^{-3} (b) The dimension of energy is L^{-2}
(c) The dimension of power is L^{-5} (d) The dimension of linear momentum is L^{-1}

Ans. (a, b, d)

5. A cylindrical capillary tube of 0.2 mm radius is made by joining two capillaries T_1 and T_2 of different materials having water contact angles of 0° and 60° , respectively. The capillary tube is dipped vertically in water in two different configurations, case I and II as shown in figure. Which of the following option(s) is(are) correct? (Surface tension of water = 0.075 N/m, density of water = 1000 kg/m^3 , take $g = 10 \text{ m/s}^2$)

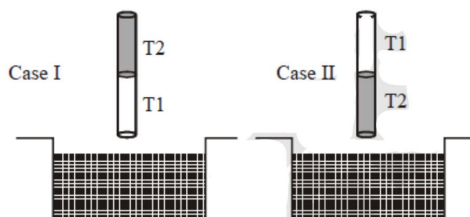

- (a) The correction in the height of water column raised in the tube, due to weight of water contained in the meniscus, will be different for both cases.
(b) For case I, if the capillary joint is 5 cm above the water surface, the height of water column raised in the tube will be more than 8.75 cm. (Neglect the weight of the water in the meniscus)
(c) For case I, if the joint is kept at 8 cm above the water surface, the height of water column in the tube will be 7.5 cm. (Neglect the weight of the water in the meniscus)
(d) For case II, if the capillary joint is 5 cm above the water surface, the height of water column raised in the tube will be 3.75 cm. (Neglect the weight of the water in the meniscus)

Ans. (a, c, d)

6. Two identical moving coil galvanometer have 10Ω resistance and full scale deflection at $2 \mu\text{A}$ current. One of them is converted into a voltmeter of 100 mV full scale reading and the other into an Ammeter of 1 mA full scale current using appropriate resistors. These are then used to measure the voltage and current in the Ohm's law experiment with $R = 1000 \Omega$ resistor by using an ideal cell. Which of the following statement(s) is/are correct?
- (a) The measured value of R will be $978 \Omega < R < 982 \Omega$.
(b) The resistance of the Voltmeter will be $100 \text{ k}\Omega$.
(c) The resistance of the Ammeter will be 0.02Ω (round off to 2nd decimal place)
(d) If the ideal cell is replaced by a cell having internal resistance of 5Ω then the measured value of R will be more than 1000Ω .

Ans. (a, c)

7. A charged shell of radius R carries a total charge Q . Given Φ as the flux of electric field through a closed cylindrical surface of height h , radius r and with its center same as that of the shell. Here, center of the cylinder is a point on the axis of the cylinder which is equidistant from its top and bottom surfaces. Which of the following option(s) is/are correct? [ϵ_0 is the permittivity of free space]
- (a) If $h > 2R$ and $r > R$ then $\Phi = \frac{Q}{\epsilon_0}$ (b) \vec{F}
(c) If $h > 2R$ and $r = \frac{4R}{5}$ then $\Phi = \frac{Q}{5\epsilon_0}$ (d) If $h > 2R$ and $r = \frac{3R}{5}$ then $\Phi = \frac{Q}{5\epsilon_0}$

Ans. (a, b, d)

8. A conducting wire of parabolic shape, initially $y = x^2$, is moving with velocity $\vec{V} = V_0 \hat{i}$ in a non-uniform magnetic field $\vec{B} = B_0 \left(1 + \left(\frac{y}{L} \right)^\beta \right) \hat{k}$, as shown in figure. If V_0 , B_0 , L and β are positive constants and

$\Delta\phi$ is the potential difference developed between the ends of the wire, then the correct statement(s) is/are:

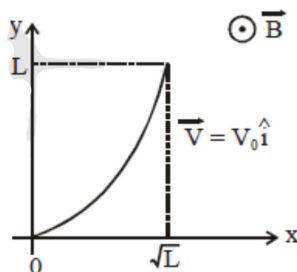

- (a) $|\Delta\phi|$ remains the same if the parabolic wire is replaced by a straight wire, $y = x$ initially, of length $\sqrt{2}L$
- (b) $|\Delta\phi|$ is proportional to the length of the wire projected on the y-axis.
- (c) $|\Delta\phi| = \frac{1}{2} B_0 V_0 L$ for $\beta = 0$
- (d) $|\Delta\phi| = \frac{4}{3} B_0 V_0 L$ for $\beta = 2$

Ans. (a, b, d)

SECTION-3 : (Maximum Marks: 18)

- This section contains **SIX (06)** questions. The answer to each question is a **NUMERICAL VALUE**.
- For each question, enter the correct numerical value of the answer using the mouse and the on-screen virtual numeric keypad in the place designated to enter the answer. If the numerical value has more than two decimal places, **truncate/round-off** the value to **TWO** decimal places.
- Answer to each question will be evaluated according to the following marking scheme:
Full Marks : +3 If ONLY the correct numerical value is entered.
Zero Marks : 0 In all other cases.

1. A block of weight 100 N is suspended by copper and steel wires of same cross sectional area 0.5 cm^2 and, length $\sqrt{3} \text{ m}$ and 1 m , respectively. Their other ends are fixed on a ceiling as shown in figure. The angles subtended by copper and steel wires with ceiling are 30° and 60° , respectively. If elongation in copper wire is (Δl_c) and elongation in steel wire is (Δl_s) , then the ratio $\frac{\Delta l_c}{\Delta l_s}$ is _____.

[Young's modulus for copper and steel are $1 \times 10^{11} \text{ N/m}^2$ and $2 \times 10^{11} \text{ N/m}^2$ respectively]

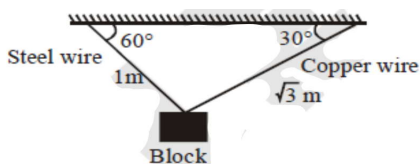

Ans. (2.00)

2. A planar structure of length L and width W is made of two different optical media of refractive indices $n_1 = 1.5$ and $n_2 = 1.44$ as shown in figure. If $L \gg W$, a ray entering from end AB will emerge from end CD only if the total internal reflection condition is met inside the structure. For $L = 9.6$ m, if the incident angle θ is varied, the maximum time taken by a ray to exit the plane CD is $t \times 10^{-9}$ s, where t is ____.
[Speed of light $c = 3 \times 10^8$ m/s]

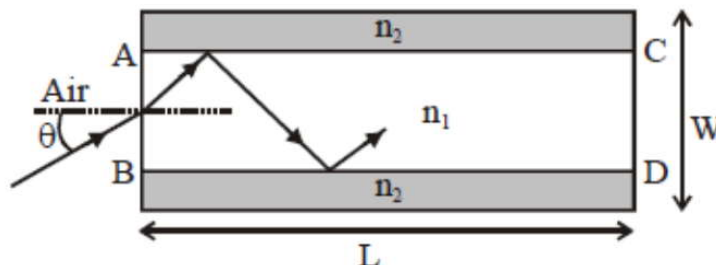

Ans. (50.00)

3. A particle is moved along a path $AB-BC-CD-DE-EF-FA$, as shown in figure, in presence of a force $\vec{F} = (\alpha y\hat{i} + 2\alpha x\hat{j})\text{N}$, where x and y are in meter and $\alpha = -1 \text{ N/m}^{-1}$. The work done on the particle by this force \vec{F} will be ____ Joule.

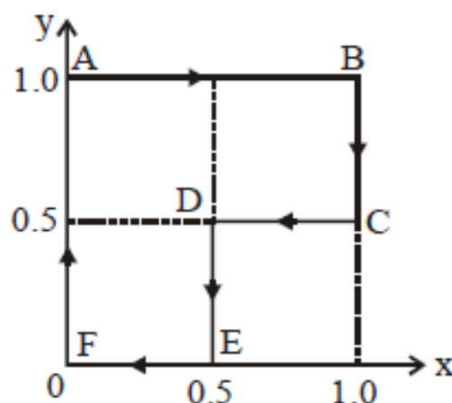

Ans. (0.75)

4. A parallel plate capacitor of capacitance C has spacing d between two plates having area A . The region between the plates is filled with N dielectric layers, parallel to its plates, each with thickness $\delta = \frac{d}{N}$. The dielectric constant of the m^{th} layer is $K_m = K\left(1 + \frac{m}{N}\right)$. For a very large $N (> 10^3)$, the capacitance C is $\alpha \left(\frac{K \epsilon_0 A}{d \ln 2}\right)$. The value of α will be ____.
[ϵ_0 is the permittivity of free space]

Ans. (1.00)

5. A train S1, moving with a uniform velocity of 108 km/h, approaches another train S2 standing on a platform. An observer O moves with a uniform velocity of 36 km/h towards S2, as shown in figure. Both the trains are blowing whistles of same frequency 120 Hz. When O is 600 m away from S2 and distance between S1 and S2 is 800 m, the number of beats heard by O is ____.

[Speed of the sound = 330 m/s]

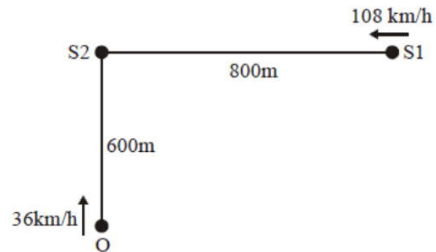

Ans. (8.12 to 8.13)

6. A liquid at 30°C is poured very slowly into a Calorimeter that is at temperature of 110°C. The boiling temperature of the liquid is 80°C. It is found that the first 5 gm of the liquid completely evaporates. After pouring another 80 gm of the liquid the equilibrium temperature is found to be 50°C. The ratio of the Latent heat of the liquid to its specific heat will be ____ °C.

[Neglect the heat exchange with surrounding]

Ans. (270.00)

PART-2 : CHEMISTRY

SECTION-1 : (Maximum Marks : 12)

- This section contains **FOUR (04)** questions.
- Each question has **FOUR** options. **ONLY ONE** of these four options is the correct answer.
- For each question, choose the option corresponding to the correct answer.
- Answer to each question will be evaluated according to the following marking scheme :
Full Marks : +3 If **ONLY** the correct option is chosen.
Zero Marks : 0 If none of the options is chosen (i.e. the question is unanswered)
Negative Marks : -1 In all other cases

1. Molar conductivity (Λ_m) of aqueous solution of sodium stearate, which behaves as a strong electrolyte, is recorded at varying concentration(c) of sodium stearate. Which one of the following plots provides the correct representation of micelle formation in the solution?
(Critical micelle concentration (CMC) is marked with an arrow in the figures.)

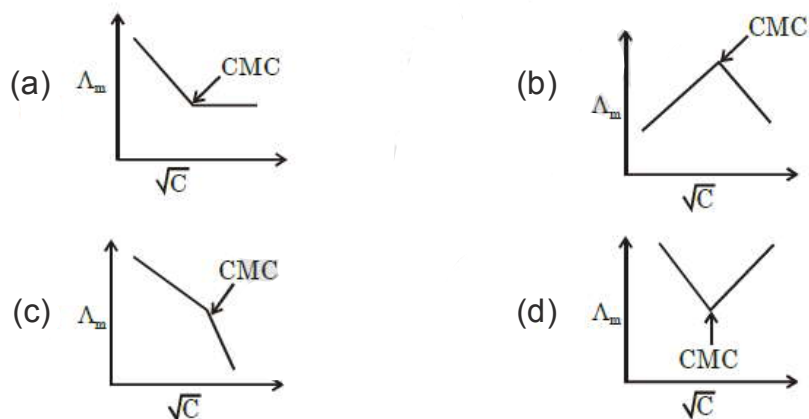

Ans. (c)

2. The correct order of acid strength of the following carboxylic acids is –

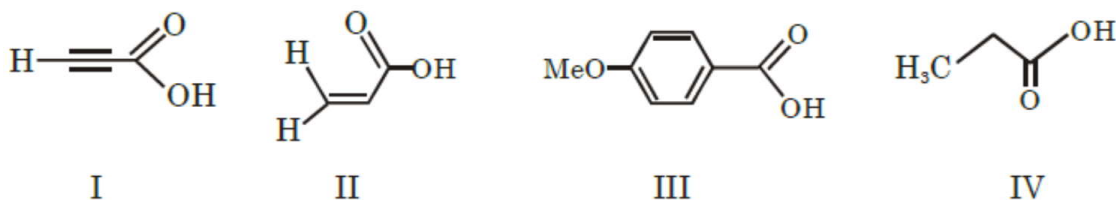

- (a) I > III > II > IV (b) III > II > I > IV (c) II > I > IV > III (d) I > II > III > IV

Ans. (d)

3. Calamine, malachite, magnetite and cryolite, respectively are

- (a) $ZnSO_4$, $CuCO_3$, Fe_2O_3 , AlF_3 (b) $ZnCO_3$, $CuCO_3 \cdot Cu(OH)_2$, Fe_3O_4 , Na_3AlF_6
 (c) $ZnSO_4$, $Cu(OH)_2$, Fe_3O_4 , Na_3AlF_6 (d) $ZnCO_3$, $CuCO_3$, Fe_2O_3 , Na_3AlF_6

Ans. (b)

4. The green colour produced in the borax bead test of a chromium(III) salt is due to -

- (a) $Cr(BO_2)_3$ (b) CrB (c) $Cr_2(B_4O_7)_3$ (d) Cr_2O_3

Ans. (a)

SECTION-2 : (Maximum Marks: 32)

- This section contains EIGHT (08) questions.
- Each question has FOUR options. ONE OR MORE THAN ONE of these four option(s) is (are) correct answer(s).
- For each question, choose the option(s) corresponding to (all) the correct answer(s)
- Answer to each question will be evaluated according to the following marking scheme:
Full Marks : +4 If only (all) the correct option(s) is (are) chosen.
Partial Marks : +3 If all the four options are correct but ONLY three options are chosen.
Partial Marks : +2 If three or more options are correct but ONLY two options are chosen and both of which are correct.
Partial Marks : +1 If two or more options are correct but ONLY one option is chosen and it is a correct option.
Zero Marks : 0 If none of the options is chosen (i.e. the question is unanswered).
Negative Marks : -1 In all other cases.
- For example, in a question, if (A), (B) and (D) are the ONLY three options corresponding to correct answers, then
 choosing ONLY (A), (B) and (D) will get +4 marks;
 choosing ONLY (A) and (B) will get +2 marks;
 choosing ONLY (A) and (D) will get +2 marks;
 choosing ONLY (B) and (D) will get +2 marks;
 choosing ONLY (A) will get +1 marks;
 choosing ONLY (B) will get +1 marks;
 choosing ONLY (D) will get +1 marks;
 choosing no option (i.e. the question is unanswered) will get 0 marks, and
 choosing any other combination of options will get -1 mark.

1. Fusion of MnO_2 with KOH in presence of O_2 produces a salt **W**. Alkaline solution of **W** upon electrolytic oxidation yields another salt **X**. The manganese containing ions present in **W** and **X**, respectively, are **Y** and **Z**. Correct statement(s) is (are)
- Y** is diamagnetic in nature while **Z** is paramagnetic
 - Both **Y** and **Z** are coloured and have tetrahedral shape
 - In both **Y** and **Z**, p-bonding occurs between p-orbitals of oxygen and d-orbitals of manganese.
 - In aqueous acidic solution, **Y** undergoes disproportionation reaction to give **Z** and MnO_2 .

Ans. (b, c, d)

2. Which of the following statement(s) is (are) correct regarding the root mean square speed (U_{rms}) and average translational kinetic energy (ϵ_{av}) of a molecule in a gas at equilibrium?
- U_{rms} is doubled when its temperature is increased four times
 - ϵ_{av} at a given temperature does not depend on its molecular mass
 - U_{rms} is inversely proportional to the square root of its molecular mass
 - ϵ_{av} is doubled when its temperature is increased four times

Ans. (a, b, c)

3. In the decay sequence :

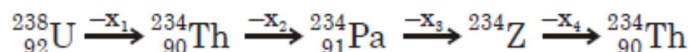

x_1, x_2, x_3 and x_4 are particles/ radiation emitted by the respective isotopes. The correct option(s) is/are-

- Z** is an isotope of uranium
- x_2 is β^-
- x_1 will deflect towards negatively charged plate
- x_3 is γ -ray

Ans. (a, b, c)

4. Which of the following statement(s) is(are) true ?
- Oxidation of glucose with bromine water gives glutamic acid
 - The two six-membered cyclic hemiacetal forms of D-(+)-glucose are called anomers
 - Hydrolysis of sucrose gives dextrorotatory glucose and laevorotatory fructose
 - Monosaccharides **cannot** be hydrolysed to give polyhydroxy aldehydes and ketones

Ans. (b, c, d)

5. A tin chloride **Q** undergoes the following reactions (not balanced)

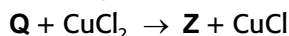

X is a monoanion having pyramidal geometry. Both **Y** and **Z** are neutral compounds. Choose the correct option(s).

- The central atoms in **X** is sp^3 hybridized
- The oxidation state of the central atom in **Z** is +2
- The central atom in **Z** has one lone pair of electrons
- There is a coordinate bond in **Y**

Ans. (a, d)

6. Choose the correct option(s) for the following set of reactions

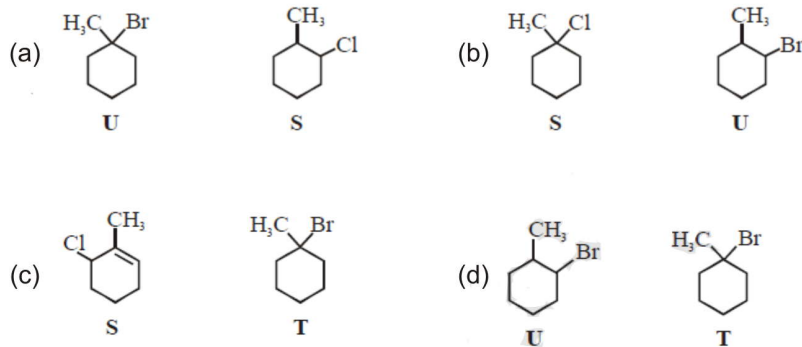
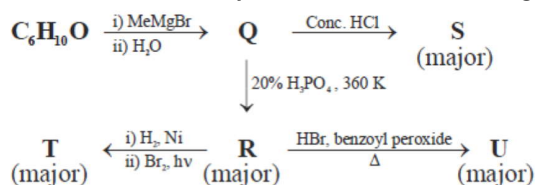

Ans. (b, d)

7. Each of the following options contains a set of four molecules. Identify the option(s) where all four molecules possess permanent dipole moment at room temperature.

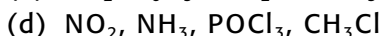
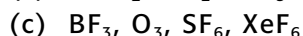
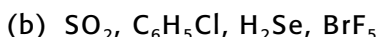
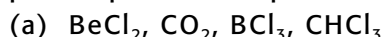

Ans. (b, d)

8. Choose the reaction(s) from the following options, for which the standard enthalpy of reaction is equal to the standard enthalpy of formation.

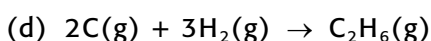
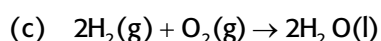
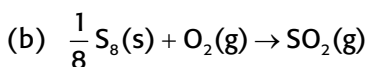
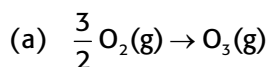

Ans. (a, b)

SECTION-3 : (Maximum Marks: 18)

- This section contains **SIX (06)** questions. The answer to each question is a **NUMERICAL VALUE**.
- For each question, enter the correct numerical value of the answer using the mouse and the on-screen virtual numeric keypad in the place designated to enter the answer. If the numerical value has more than two decimal places, **truncate/round-off** the value to **Two** decimal places.
- Answer to each question will be evaluated according to the following marking scheme:

Full Marks : +3 If ONLY the correct numerical value is entered.

Zero Marks : 0 In all other cases.

1. For the following reaction, the equilibrium constant K_c at 298 K is 1.6×10^{17} .

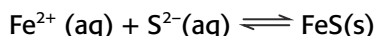

When equal volumes of 0.06 M $\text{Fe}^{2+}(\text{aq})$ and 0.2 M $\text{S}^{2-}(\text{aq})$ solutions are mixed, the equilibrium concentration of $\text{Fe}^{2+}(\text{aq})$ is found to be $Y \times 10^{-17}$ M. The value of Y is -----

Ans. (8.92 or 8.93)

2. Among B_2H_6 , $\text{B}_3\text{N}_3\text{H}_6$, N_2O , N_2O_4 , $\text{H}_2\text{S}_2\text{O}_3$ and $\text{H}_2\text{S}_2\text{O}_8$, the total number of molecules containing covalent bond between two atoms of the same kind is -----

Ans. (4.00)

3. Consider the kinetic data given in the following table for the reaction $\text{A} + \text{B} + \text{C} \rightarrow \text{Product}$.

Experiment No.	[A] (mol dm^{-3})	[B] (mol dm^{-3})	[C] (mol dm^{-3})	Rate of reaction ($\text{mol dm}^{-3} \text{ s}^{-1}$)
1	0.2	0.1	0.1	6.0×10^{-5}
2	0.2	0.2	0.1	6.0×10^{-5}
3	0.2	0.1	0.2	1.2×10^{-4}
4	0.3	0.1	0.1	9.0×10^{-5}

The rate of the reaction for $[\text{A}] = 0.15 \text{ mol dm}^{-3}$, $[\text{B}] = 0.25 \text{ mol dm}^{-3}$ and $[\text{C}] = 0.15 \text{ mol dm}^{-3}$ is found to be $Y \times 10^{-5} \text{ mol dm}^{-3} \text{ s}^{-1}$. The value of Y is -----

Ans. (6.75)

4. On dissolving 0.5 g of a non-volatile non-ionic solute to 39 g of benzene, its vapor pressure decreases from 650 mm Hg to 640 mm Hg. The depression of freezing point of benzene (in K) upon addition of the solute is _____

(Given data : Molar mass and the molal freezing point depression constant of benzene are 78 g mol^{-1} and $5.12 \text{ K kg mol}^{-1}$, respectively)

Ans. (1.02 or 1.03)

5. Scheme 1 and 2 describe the conversion of P to Q and R to S, respectively. Scheme 3 describes the synthesis of T from Q and S. The total number of Br atoms in a molecule of T is _____

Scheme 1 :

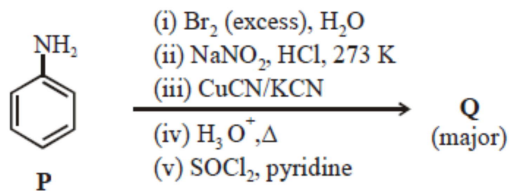

Scheme 2 :

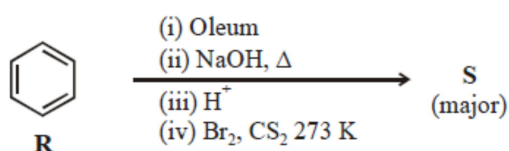

Scheme 3 :

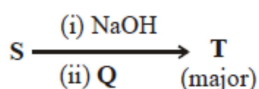

6. At 143 K, the reaction of XeF_4 with O_2F_2 produces a xenon compound Y. The total number of lone pair(s) of electrons present on the whole molecule of Y is _____

Ans. (19.00)

PART-3 : MATHEMATICS

SECTION-1 : (Maximum Marks : 12)

- This section contains **FOUR (04)** questions.
- Each question has **FOUR** options. **ONLY ONE** of these four options is the correct answer.
- For each question, choose the option corresponding to the correct answer.
- Answer to each question will be evaluated according to the following marking scheme :

Full Marks : +3 If **ONLY** the correct option is chosen.

Zero Marks : 0 If none of the options is chosen (i.e. the question is unanswered)

Negative Marks : -1 In all other cases

1. Let $M = \begin{bmatrix} \sin^4 \theta & -1 - \sin^2 \theta \\ 1 + \cos^2 \theta & \cos^4 \theta \end{bmatrix} = \alpha I + \beta M^{-1}$

Where $\alpha = \alpha(\theta)$ and $\beta = \beta(\theta)$ are real number, and I is the 2×2 identity matrix. If

α^* is the minimum of the set $\{\alpha(\theta) : \theta \in [0, 2\pi)\}$ and

β^* is the minimum of the set $\{\beta(\theta) : \theta \in [0, 2\pi)\}$,

Then the value of $\alpha^* + \beta^*$ is

- (a) $-\frac{37}{16}$ (b) $-\frac{29}{16}$ (c) $-\frac{31}{16}$ (d) $-\frac{17}{16}$

Ans. (b)

2. A line $y = mx + 1$ intersects the circle $(x - 3)^2 + (y + 2)^2 = 25$ at the points P and Q. If the midpoint of the line segment PQ has x-coordinate $-\frac{3}{5}$, then which one of the following options is correct ?

- (a) $6 \leq m < 8$ (b) $2 \leq m < 4$ (c) $4 \leq m < 6$ (d) $-3 \leq m < -1$

Ans. (b)

3. Let S be the set of all complex numbers z satisfying $|z - 2 + i| \geq \sqrt{5}$. If the complex number z_0 is such that

$\frac{1}{|z_0 - 1|}$ is the maximum of the set $\left\{ \frac{1}{|z - 1|} : z \in S \right\}$, then the principal argument of $\frac{4 - z_0 - \bar{z}_0}{z_0 - \bar{z}_0 + 2i}$ is

- (a) $\frac{\pi}{4}$ (b) $-\frac{\pi}{2}$ (c) $\frac{3\pi}{4}$ (d) $\frac{\pi}{2}$

Ans. (b)

4. The area of the region $\{(x, y) : xy \leq 8, 1 \leq y \leq x^2\}$ is

- (a) $8 \log_e 2 - \frac{14}{3}$ (b) $16 \log_e 2 - \frac{14}{3}$ (c) $16 \log_e 2 - 6$ (d) $8 \log_e 2 - \frac{7}{3}$

Ans (b)

SECTION-2 : (Maximum Marks: 32)

- This section contains **EIGHT (08)** questions.
- Each question has **FOUR** options. **ONE OR MORE THAN ONE** of these four option(s) is (are) correct answer(s).
- For each question, choose the option(s) corresponding to (all) the correct answer(s)
- Answer to each question will be evaluated according to the following marking scheme:
Full Marks : +4 If only (all) the correct option(s) is (are) chosen.
Partial Marks : +3 If all the four options are correct but **ONLY** three options are chosen.
Partial Marks : +2 If three or more options are correct but **ONLY** two options are chosen and both of which are correct.
Partial Marks : +1 If two or more options are correct but **ONLY** one option is chosen and it is a correct option.
Zero Marks : 0 If none of the options is chosen (i.e. the question is unanswered).
Negative Marks : -1 In all other cases.
- For example, in a question, if (A), (B) and (D) are the **ONLY** three options corresponding to correct answers, then
 choosing **ONLY** (A), (B) and (D) will get +4 marks;
 choosing **ONLY** (A) and (B) will get +2 marks;
 choosing **ONLY** (A) and (D) will get +2 marks;
 choosing **ONLY** (B) and (D) will get +2 marks;
 choosing **ONLY** (A) will get +1 marks;
 choosing **ONLY** (B) will get +1 marks;
 choosing **ONLY** (D) will get +1 marks;
 choosing no option (i.e. the question is unanswered) will get 0 marks, and
 choosing any other combination of options will get -1 mark.

1. There are three bags B_1 , B_2 and B_3 . The bag B_1 contains 5 red and 5 green balls, B_2 contains 3 red and 5 green balls, and B_3 contains 5 red and 3 green balls, Bags B_1 , B_2 and B_3 have probabilities $\frac{3}{10}$, $\frac{3}{10}$ and $\frac{4}{10}$ respectively of being chosen. A bag is selected at random and a ball is chosen at random from the bag. Then which of the following options is/are correct?
- (a) Probability that the selected bag is B_3 and the chosen ball is green equals $\frac{3}{10}$
- (b) Probability that the chosen ball is green equals $\frac{39}{80}$
- (c) Probability that the chosen ball is green, given that the selected bag is B_3 , equals $\frac{3}{8}$
- (d) Probability that the selected bag is B_3 , given that the chosen balls is green, equals $\frac{5}{13}$

Ans. (b, c)

2. Define the collections $\{E_1, E_2, E_3, \dots\}$ of ellipses and $\{R_1, R_2, R_3, \dots\}$ of rectangles as follows :

$$E_1 : \frac{x^2}{9} + \frac{y^2}{4} = 1;$$

R_1 : rectangle of largest area, with sides parallel to the axes, inscribed in E_1 ;

E_n : ellipse

$$\frac{x^2}{a_n^2} + \frac{y^2}{b_n^2} = 1 \text{ of largest area inscribed in } R_{n-1}, n > 1 ;$$

R_n : rectangle of largest area, with sides parallel to the axes, inscribed in $E_n, n > 1$.

Then which of the following options is/are correct?

- (a) The eccentricities of E_{18} and E_{19} are NOT equal

- (b) The distance of a focus from the centre in E_9 is $\frac{\sqrt{5}}{32}$

(c) The length of latus rectum of E_9 is $\frac{1}{6}$

(4) $\sum_{n=1}^N (\text{area of } R_n) < 24$, for each positive integer N

Ans. (c, d)

3. Let $m = \begin{vmatrix} 0 & 1 & a \\ 1 & 2 & 3 \\ 3 & b & 1 \end{vmatrix}$ and $\text{adj } M = \begin{bmatrix} -1 & 1 & -1 \\ 8 & -6 & 2 \\ -5 & 3 & -1 \end{bmatrix}$ where a and b are real numbers. Which of the following options

is/are correct?

(a) $a + b = 3$

(b) $\det(\text{adj}M^2) = 81$

(c) $(\text{adj}M)^{-1} + \text{adj}M^{-1} = -M$

(d) If $M \begin{bmatrix} \alpha \\ \beta \\ \gamma \end{bmatrix} = \begin{bmatrix} 1 \\ 2 \\ 3 \end{bmatrix}$, then $\alpha - \beta + \gamma = 3$

Ans. (a, c, d)

4. Let $f : \mathbb{R} \rightarrow \mathbb{R}$ be given by

$$f(x) = \begin{cases} x^5 + 5x^4 + 10x^3 + 10x^2 + 3x + 1, & x < 0; \\ x^2 - x + 1, & 0 \leq x < 1; \\ \frac{2}{3}x^3 - 4x^2 + 7x - \frac{8}{3}, & 1 \leq x < 3; \\ (x-2)\log_e(x-2) - x + \frac{10}{3}, & x \geq 3 \end{cases}$$

Then which of the following options is/are correct ?

(a) f' has a local maximum at $x = 1$

(b) f is onto

(c) f is increasing on $(-\infty, 0)$

(d) f' is NOT differentiable at $x = 1$

Ans. (a, b, d)

5. Let α and β be the roots of $x^2 - x - 1 = 0$, with $\alpha > \beta$. For all positive integers n , define

$$a_n = \frac{\alpha^n - \beta^n}{\alpha - \beta}, n \geq 2$$

$$b_1 = 1 \text{ and } b_n = a_{n-1} + a_{n+1}, n > 2.$$

Then which of the following options is/are correct?

(a) $a_1 + a_2 + a_3 + \dots + a_n = a_{n+2} - 1$ for all $n > 1$

(b) $\sum_{n=1}^{\infty} \frac{a^n}{10^n} = \frac{10}{89}$

(c) $\sum_{n=1}^{\infty} \frac{b_n}{10^n} = \frac{8}{89}$

(d) $\alpha^n + \beta^n$ for all $n \geq 1$

Ans. (a, b, d)

6. Let Γ denote a curve $y = y(x)$ which is in the first quadrant and let the point $(1, 0)$ lie on it. Let the tangent to Γ at a point P intersect the y -axis at Y_p . If PY_p has length 1 for each point P on Γ , then which of the following options is/are correct?

(a) $y = \log_e \left(\frac{1 + \sqrt{1-x^2}}{x} \right) - \sqrt{1-x^2}$

(b) $xy - \sqrt{1-x^2} = 0$

(c) $y = -\log_e \left(\frac{1 + \sqrt{1-x^2}}{x} \right) + \sqrt{1-x^2}$

(d) $xy + \sqrt{1-x^2} = 0$

Ans. (a, d)

7. In a non-right-angled triangle ΔPQR , let p, q, r denote the lengths of the sides opposite to the angles at P, Q, R respectively. The median from R meets the side PQ at S , the perpendicular from P meets the side QR at E , and RS and PE intersect at O . If $p = \sqrt{3}, q = 1$, and the radius of the circumcircle of the ΔPQR equals 1, then which of the following options is/are correct?

(a) Area of $\Delta SOE = \frac{\sqrt{3}}{12}$

(b) Radius of incircle of $\Delta PQR = \frac{\sqrt{3}}{12}(2 - \sqrt{3})$

(c) Length of $RS = \frac{\sqrt{7}}{2}$

(d) Length of $OE = \frac{1}{6}$

Ans. (b, c, d)

8. Let L_1 and L_2 denotes the lines

$$\vec{r} = \hat{i} + \lambda(-\hat{i} + 2\hat{j} + 2\hat{k}), \lambda \in \mathbb{R} \text{ and}$$

$$\vec{r} = \mu(2\hat{i} - \hat{j} + 2\hat{k}), \mu \in \mathbb{R}$$

respectively. If L_3 is a line which is perpendicular to both L_1 and L_2 and cuts both of them, then which of the following options describe(s) L_3 ?

(a) $\vec{r} = \frac{1}{3}(2\hat{i} + \hat{k}) + t(2\hat{i} + 2\hat{j} - \hat{k}), t \in \mathbb{R}$

(b) $\vec{r} = \frac{2}{9}(2\hat{i} - \hat{j} + 2\hat{k}) + t(2\hat{i} + 2\hat{j} - \hat{k}), t \in \mathbb{R}$

(c) $\vec{r} = t(2\hat{i} + 2\hat{j} - \hat{k}), t \in \mathbb{R}$

(d) $\vec{r} = \frac{2}{9}(4\hat{i} + \hat{j} + \hat{k}) + t(2\hat{i} + 2\hat{j} - \hat{k}), t \in \mathbb{R}$

Ans. (a, b, d)

SECTION-3 : (Maximum Marks: 18)

- This section contains **SIX (06)** questions. The answer to each question is a **NUMERICAL VALUE**.
- For each question, enter the correct numerical value of the answer using the mouse and the on-screen virtual numeric keypad in the place designated to enter the answer. If the numerical value has more than two decimal places, **truncate/round-off** the value to **Two** decimal places.
- Answer to each question will be evaluated according to the following marking scheme:
Full Marks : +3 If **ONLY** the correct numerical value is entered.
Zero Marks : 0 In all other cases.

1. If $\frac{2}{\pi} \sum_{-\pi/4}^{\pi/4} \frac{dx}{(1 + e^{\sin x})(2 - \cos 2x)}$ then 2712 equals _____

Ans. (4.00)

2. Let the point B be the reflection of the point $A(2, 3)$ with respect to the line $8x - 6y - 23 = 0$. Let Γ_A and Γ_B be circles of radii 2 and 1 with centres A and B respectively. Let T be a common tangent to the circles Γ_A and Γ_B such that both the circles are on the same side of T . If C is the point of intersection of T and the line passing through A and B , then the length of the line segment AC is _____

Ans. (10.00)

3. Let $AP(a; d)$ denote the set of all the terms of an infinite arithmetic progression with first term a and common difference $d > 0$. If $AP(1; 3) \cap AP(2; 5) \cap AP(3; 7) = AP(a; d)$ then $a + d$ equals _____

Ans. (157.00)

4. Let S be the sample space of all 3×3 matrices with entries from the set $\{0, 1\}$. Let the events E_1 and E_2 be given by
 $E_1 = \{A \in S : \det A = 0\}$ and
 $E_2 = \{A \in S : \text{sum of entries of } A \text{ is } 7\}$.
If a matrix is chosen at random from S , then the conditional probability $P(E_1|E_2)$ equals ____

Ans. (0.50)

5. Three lines are given by

$$\vec{r} = \lambda \hat{i}, \lambda \in \mathbb{R}$$

$$\vec{r} = \mu(\hat{i} + \hat{j}), \mu \in \mathbb{R} \text{ and}$$

$$\vec{r} = \nu(\hat{i} + \hat{j} + \hat{k}), \nu \in \mathbb{R}$$

Let the lines cut the plane $x + y + z = 1$ at the points A, B and C respectively. If the area of the triangle ABC is Δ then the value of $(6\Delta)^2$ equals ____

Ans. (0.75)

6. Let $\omega \neq 1$ be a cube root of unity. Then the minimum of the set
 $\{|a + b\omega + c\omega^2|^2 : a, b, c \text{ distinct non-zero integers}\}$ equals ____

Ans. (3.00)